

# SKELETAL SYSTEM

The evolutionary and physiological impacts of having an **exoskeleton**.

Huge diversity





**SKELETAL SYSTEM**

# **FUNCTIONS OF SKELETAL SYSTEM**

1. Support and strength of the organism and its limbs
2. Protection of animal, especially the internal organs
3. Attachment for muscles

Kennedy, C.H. 1927. The exoskeleton as a factor in limiting and directing the evolution of insects. *Journ. Morph.* 44:267-312.

# Overall strength of an exoskeleton versus an endoskeleton

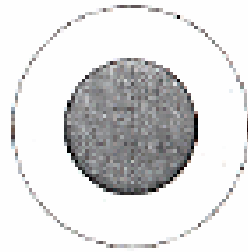

Endoskeletal  
appendage

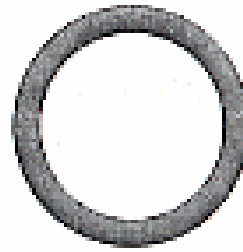

Exoskeletal  
appendage

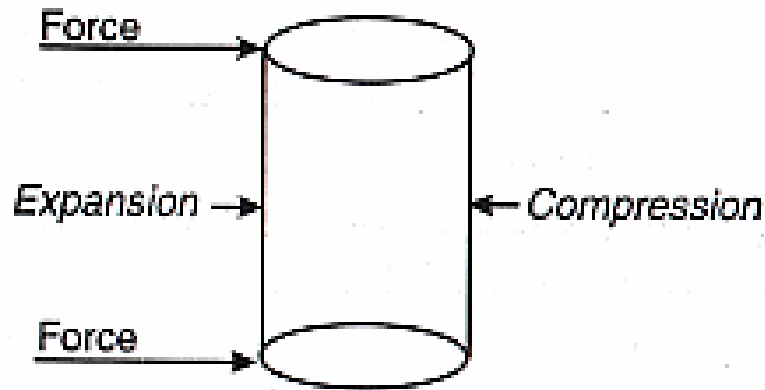

Support for body. Outside tubes that are hollow of an exoskeleton are stronger than inside, solid tubes of an endoskeleton

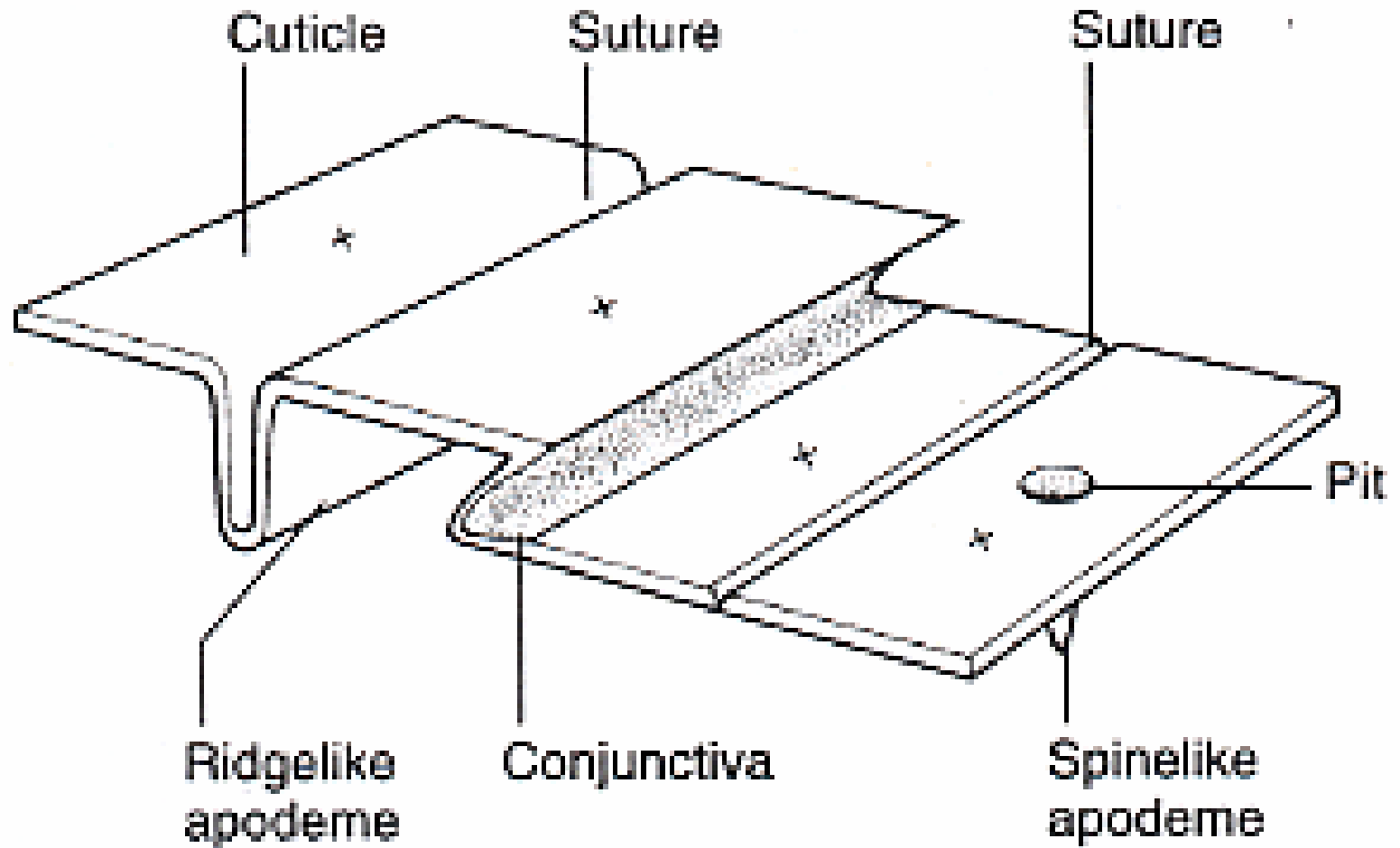

Sclerites ( tergites, pleurites and sternites)

**Apodemes**-Cuticular ingrowths or 4, deep invaginations that meet internally and form a brace for the head and for muscle attachment and found in all insects.

In the pterygote insects, however, these ingrowths start at the **tentorial pits** on the face and have evolved to form the head endoskeleton or **tentorium**.

Apodemes can take the form of being just a point-like invagination or a line (or sulcus or suture).

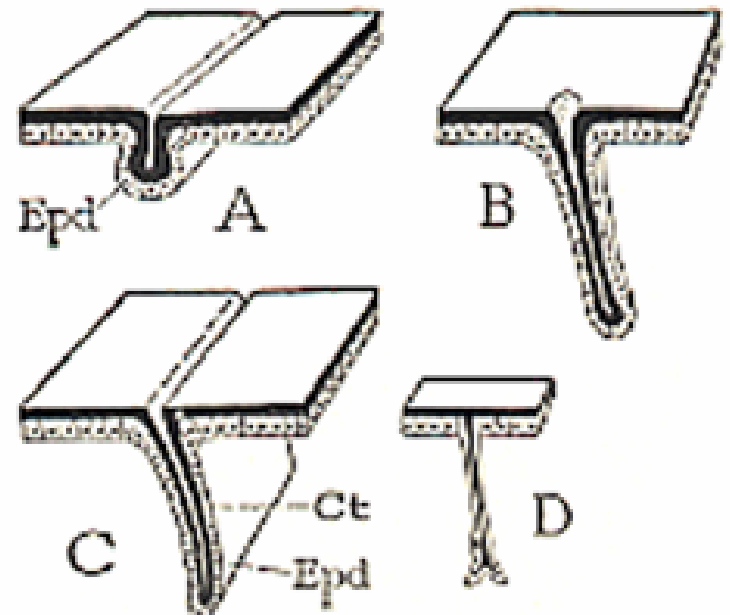

4 major apodemes provide sort of an internalized 'endoskeleton'. Gives tissue support and attachment sites for muscles.

**Tentorium----head**

**Furca-----thorax**

**Phragma-----thorax**

**Apophysis----thorax**

**Why does the head and thorax need additional support?**



# The Insect Head (Frontal)

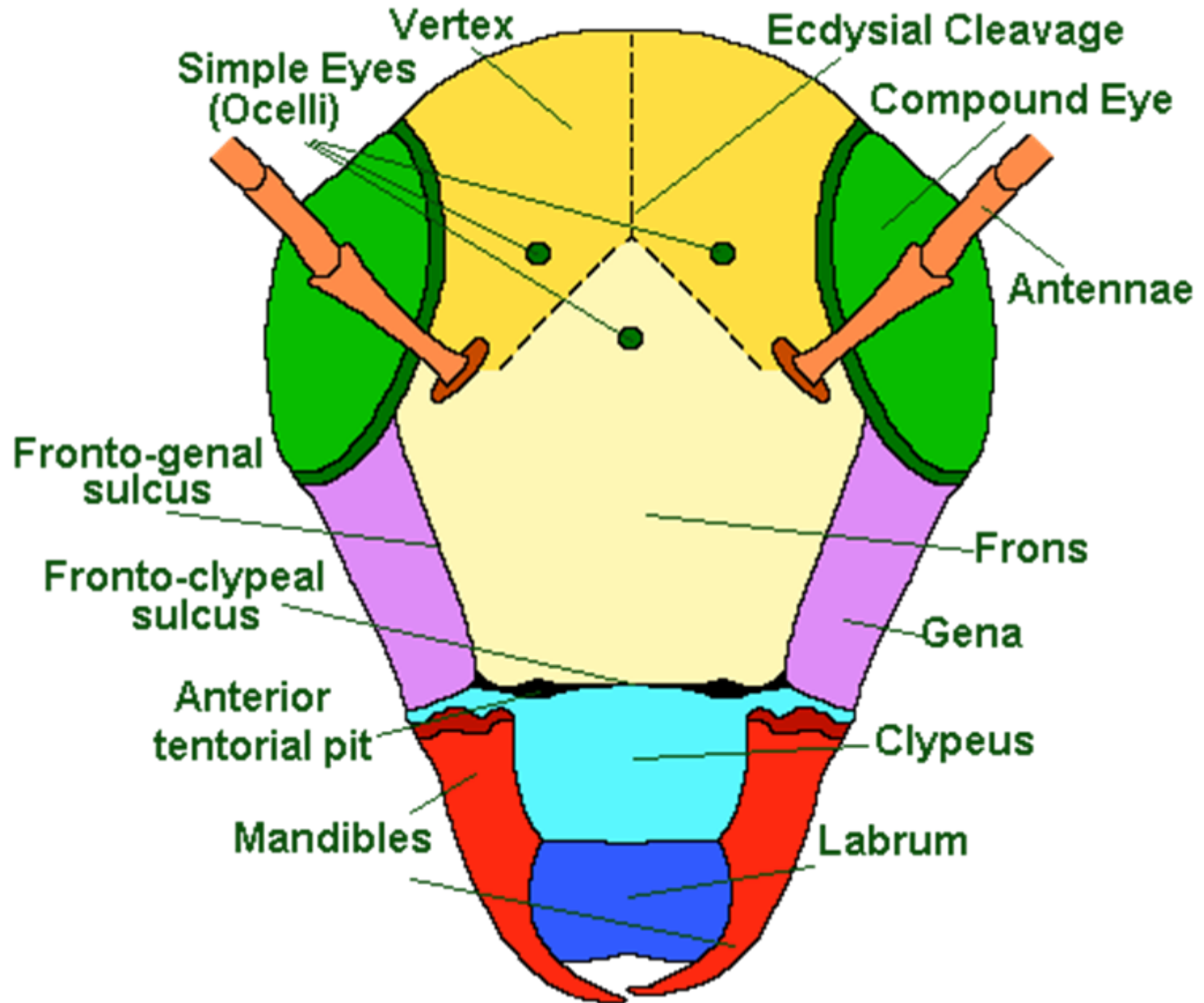

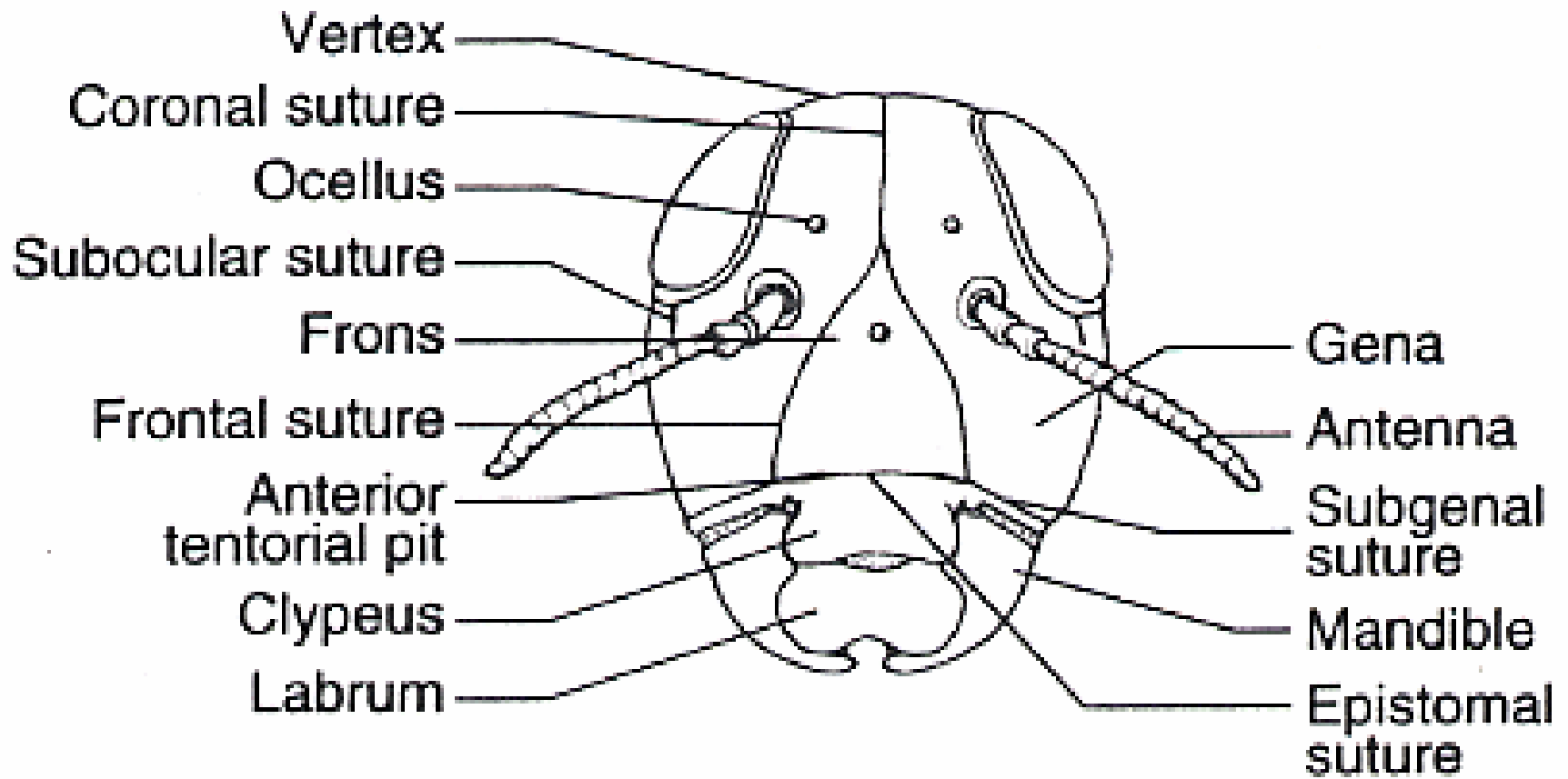

# The Insect Head (Side View)

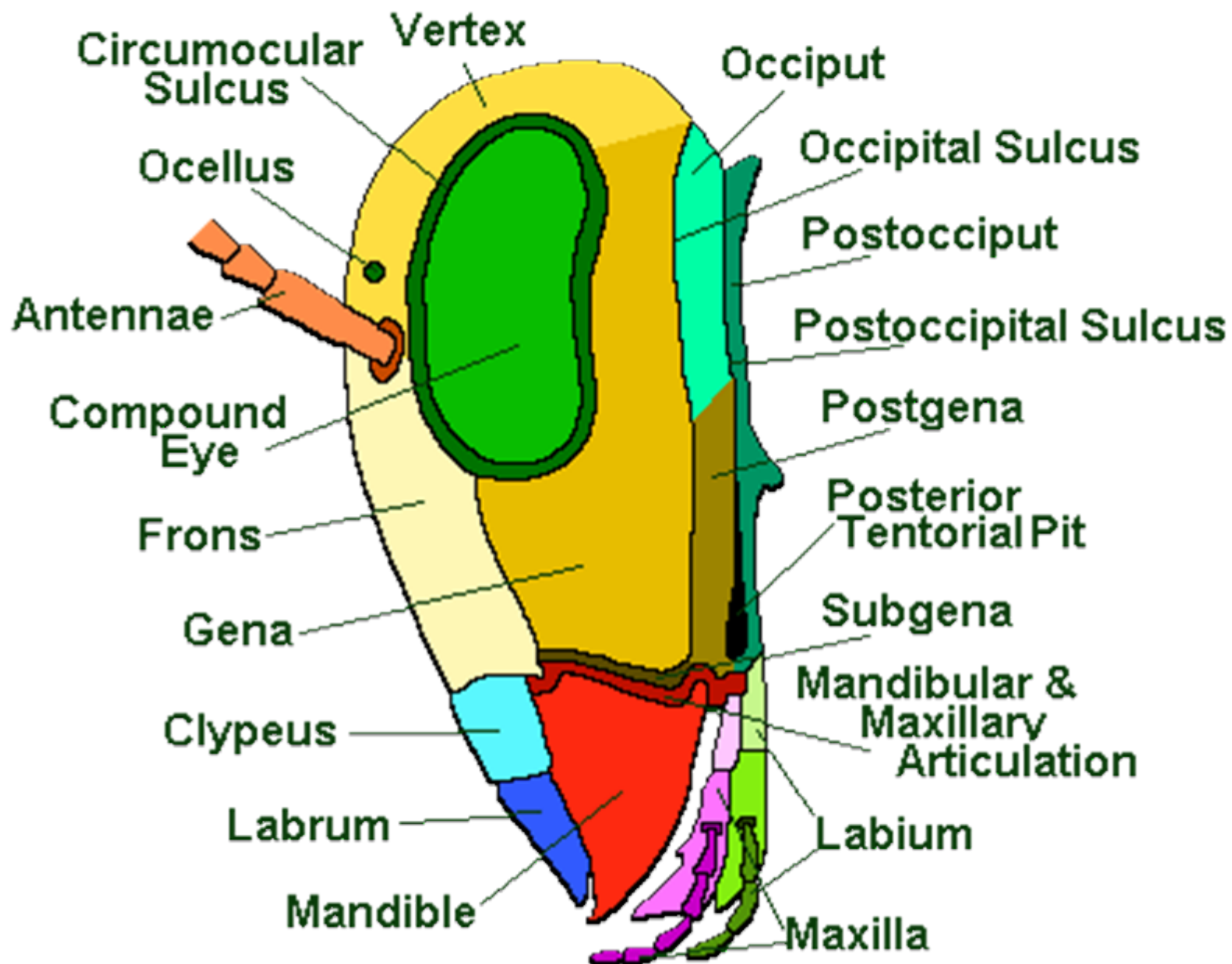

# TENTORIUM

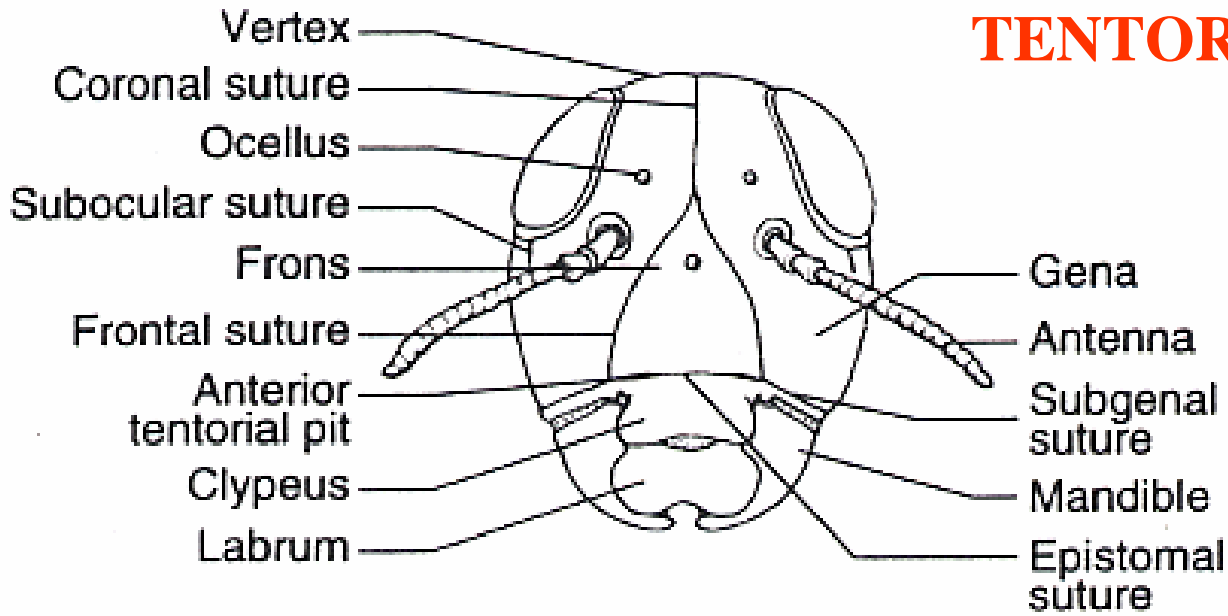

*Japyx* stained red to show tentorium

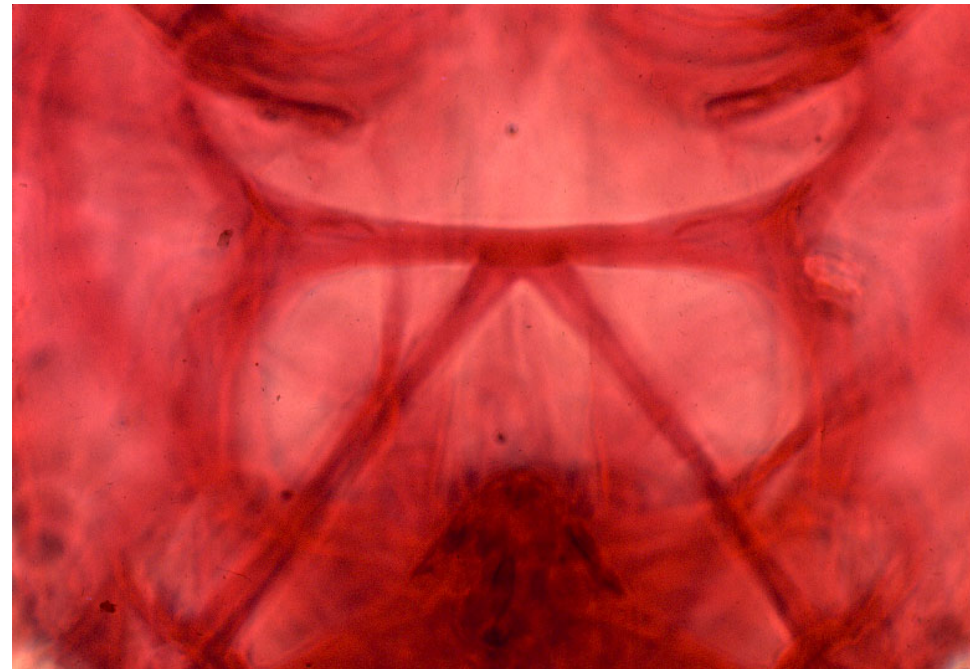
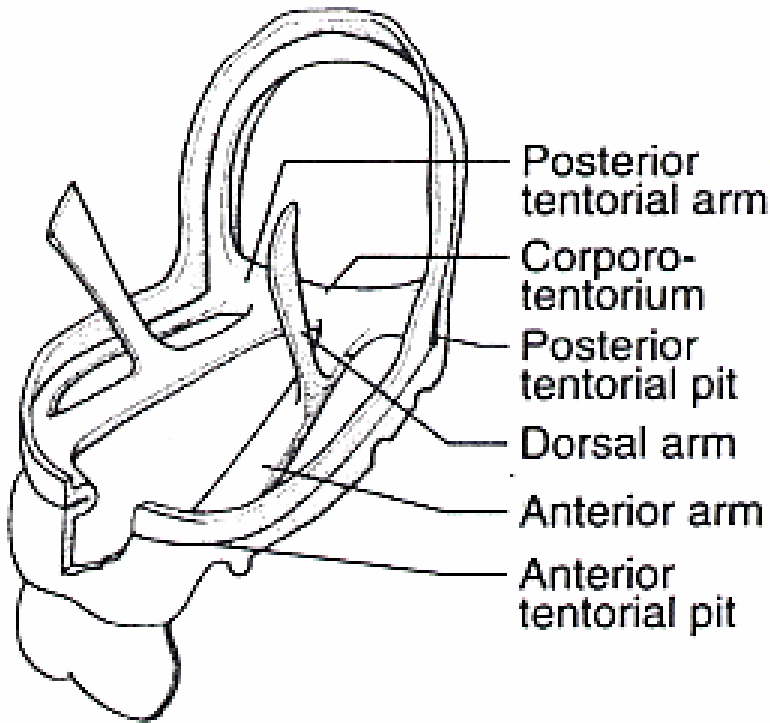

# Various modifications of the tentorium—from pg. 117 Snodgrass

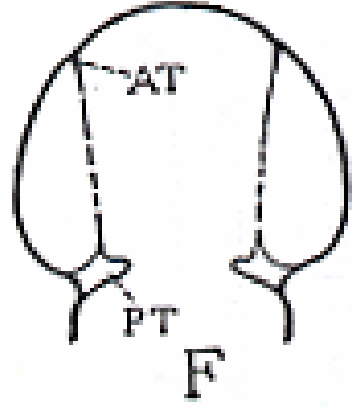
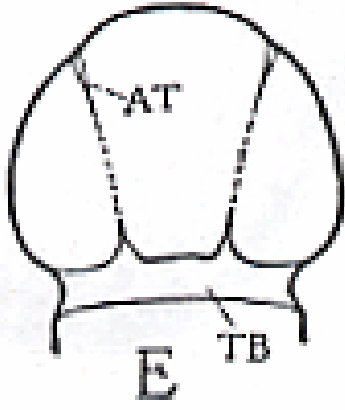
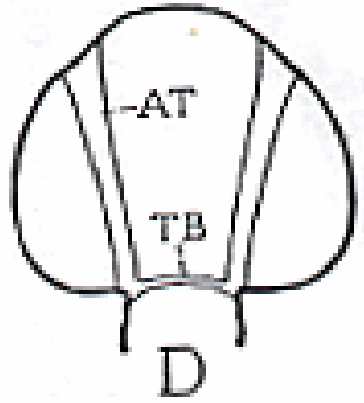
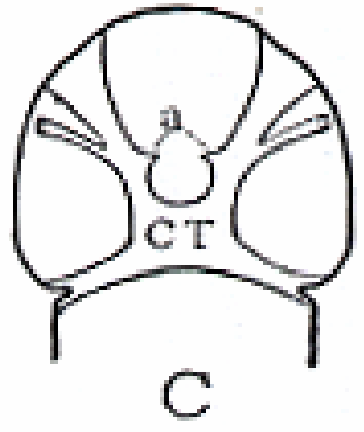
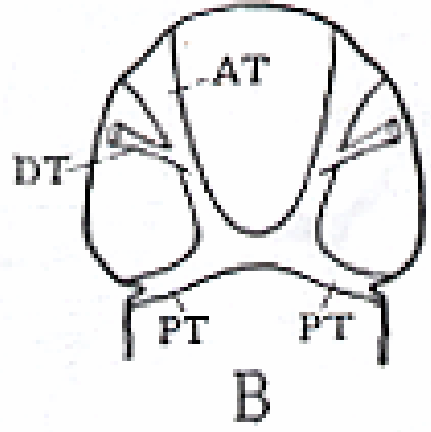
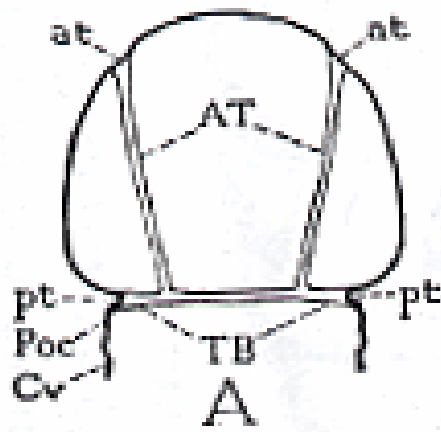

**Phragma** are transverse partitions of the endoskeleton used mainly for muscle attachment.

Phragma development in the thorax-Notice none in larva, somewhat more in the apterygote? and much more in the winged adult. The flight muscles need attachment sites, which the phragma provide.

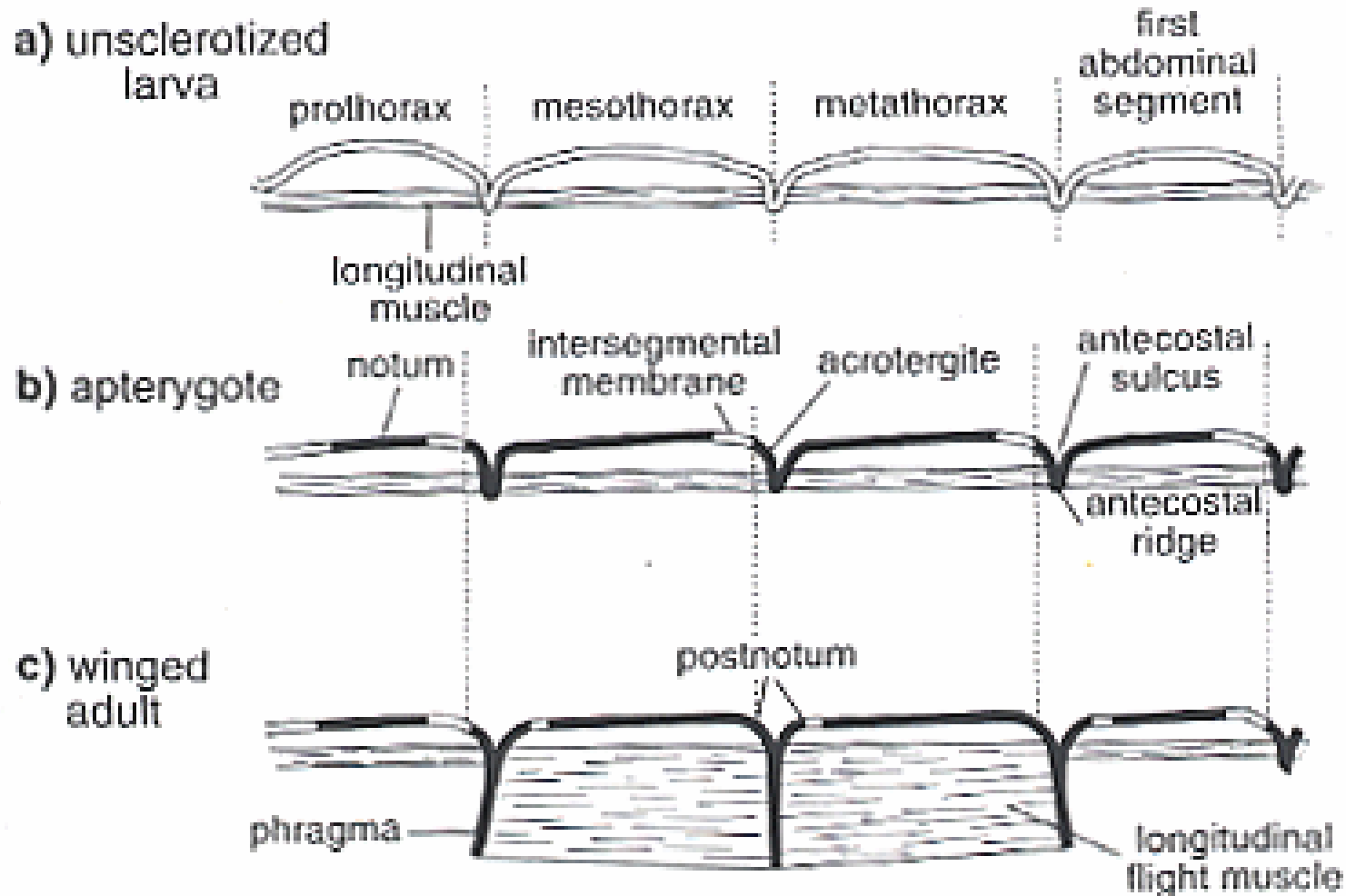

**Apophyses**-plates of the endoskeleton that provide both extra strength and muscle attachment sites for muscles in the thorax.

**Furca**-Forked endoskeletal ridge of the sternum of higher insects

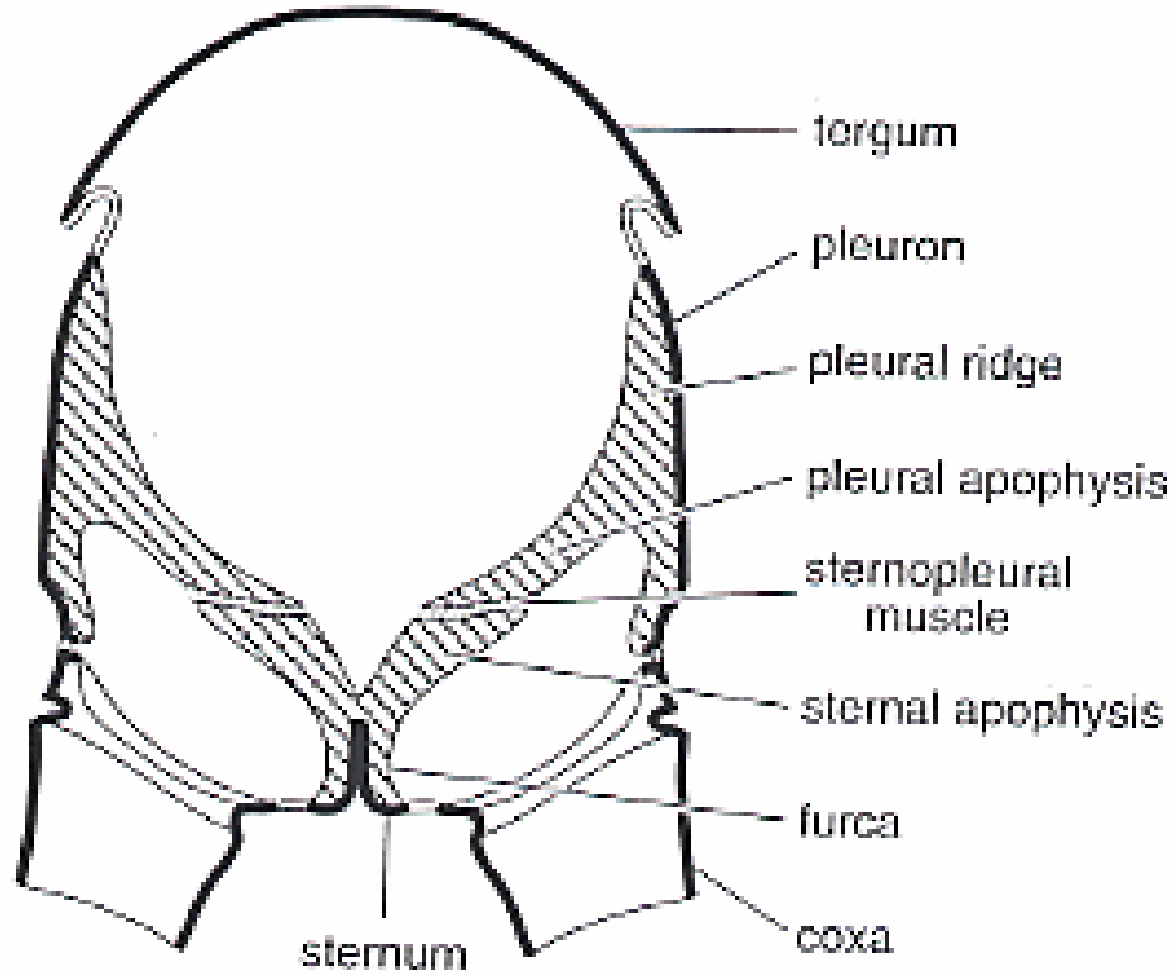

# Evolution of the furca and apophyses to support evolution of wings

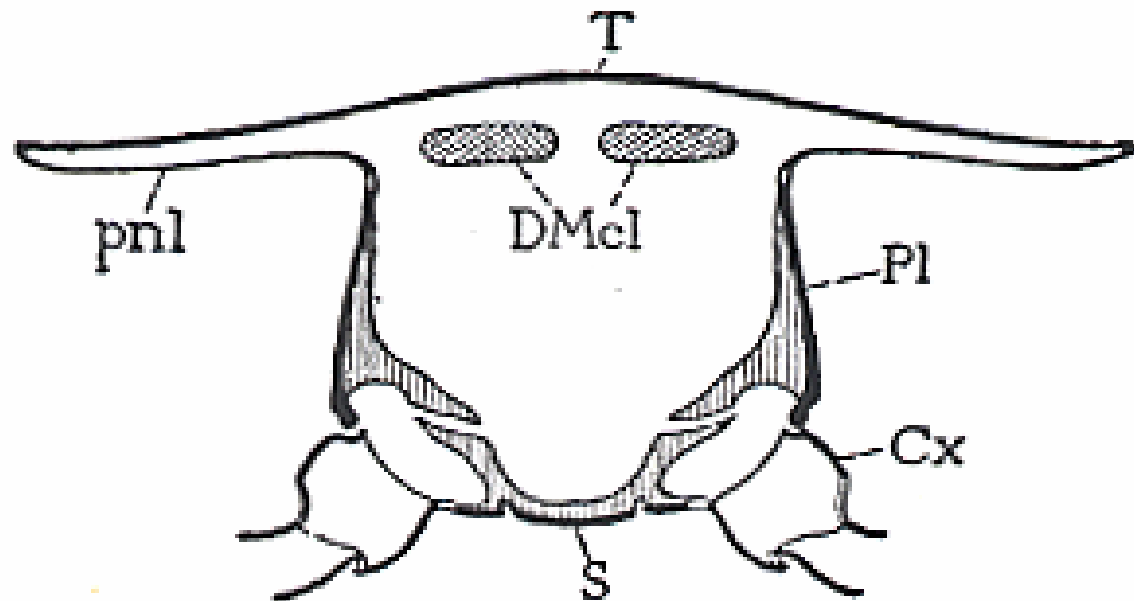

FIG. 120.—Diagrammatic cross section of a thoracic segment with paranotal extensions of the tergum.



**Apophysis** in abdomen of the lubber grasshopper. Endoskeletal ingrowths that provide for muscle attachment.



# Involvement of various apophyses for muscle attachment for muscle

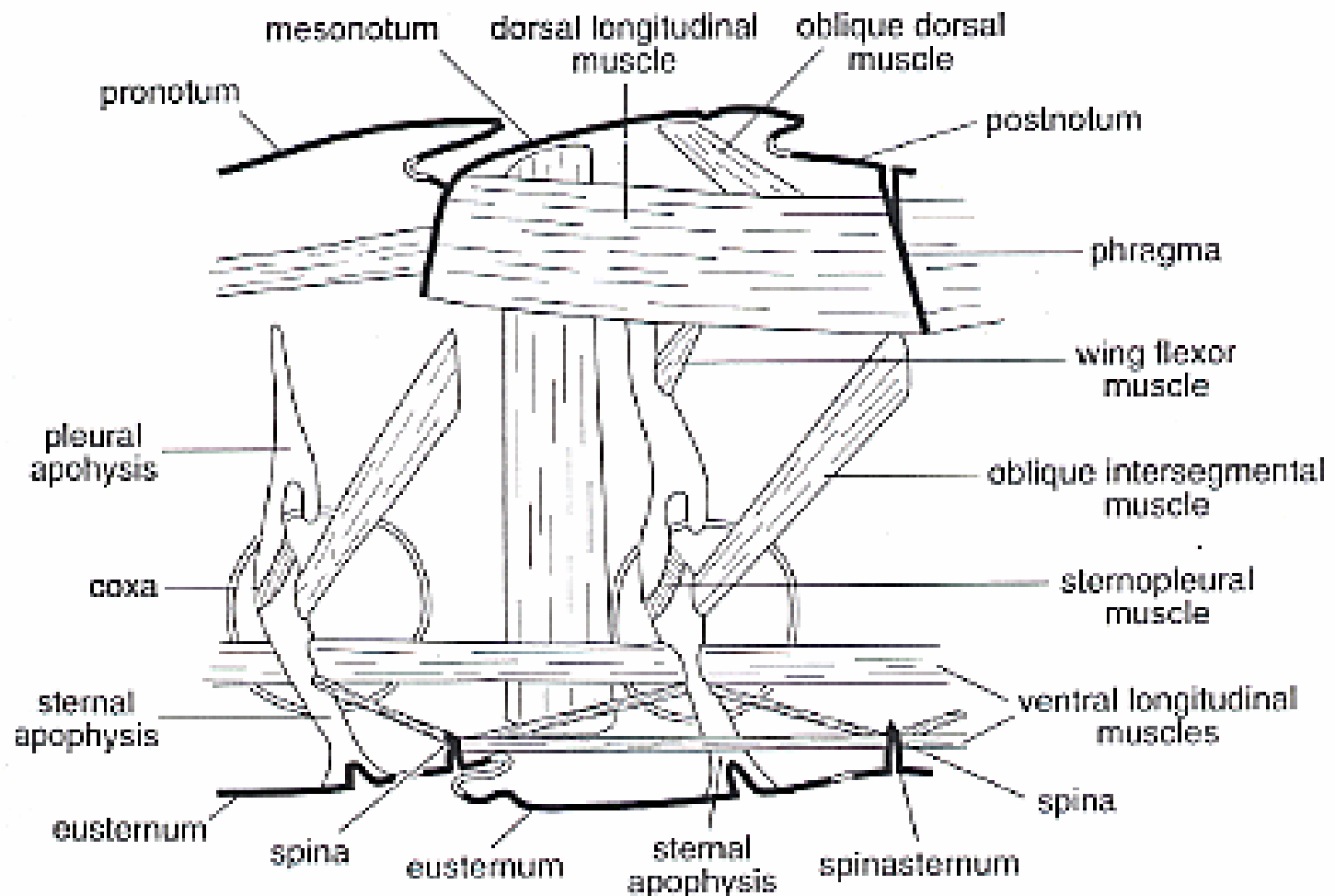

**Tonofibrillae**-definition from Snodgrass-Cuticular fibrils connecting the muscle fibers with the inner surface of the cuticula. Because of TEM we now know that these fibrils are microtubules that usually pass through the epidermal cells and are probably produced by them.

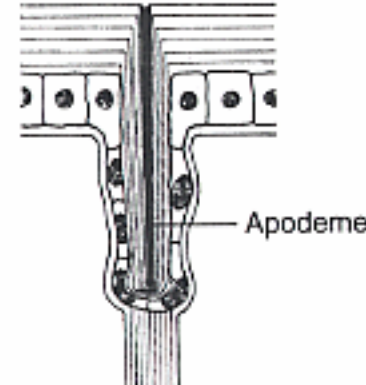
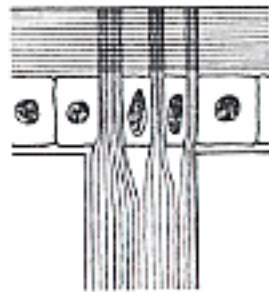
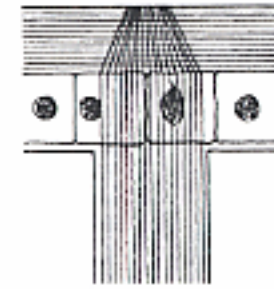
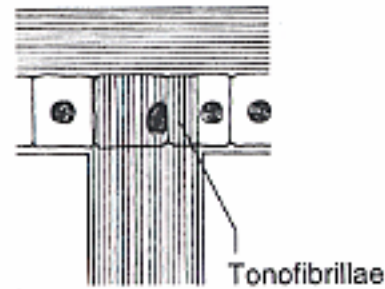
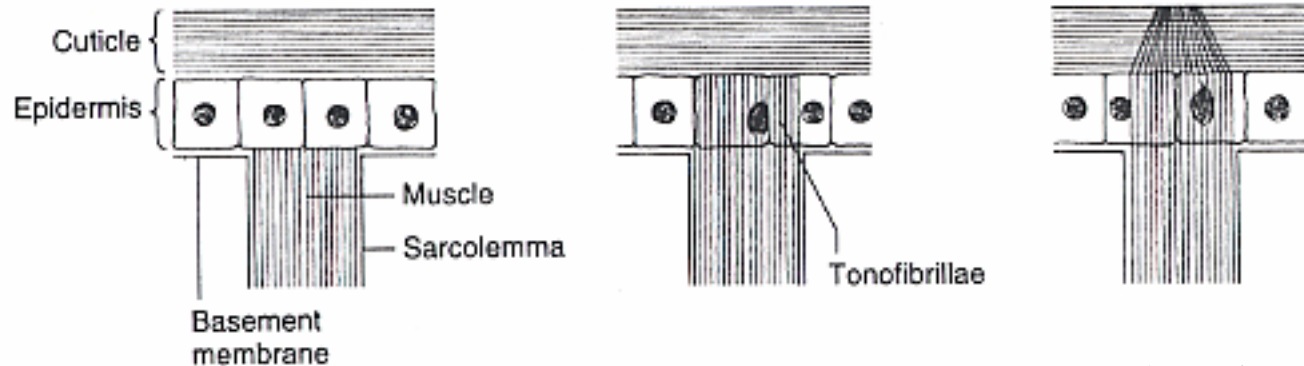

Note that in most cases the microtubules extend into the epithelial cells. Also note that the muscle can attach to the apodeme

Schematic representation of cartoon and model showing how the epidermal cells are involved in attaching the muscles to the cuticle via microtubules and thus forming tonofibrillae.

Note the microtubules extend from the muscle through the epidermal cell and to the surface of epicuticle

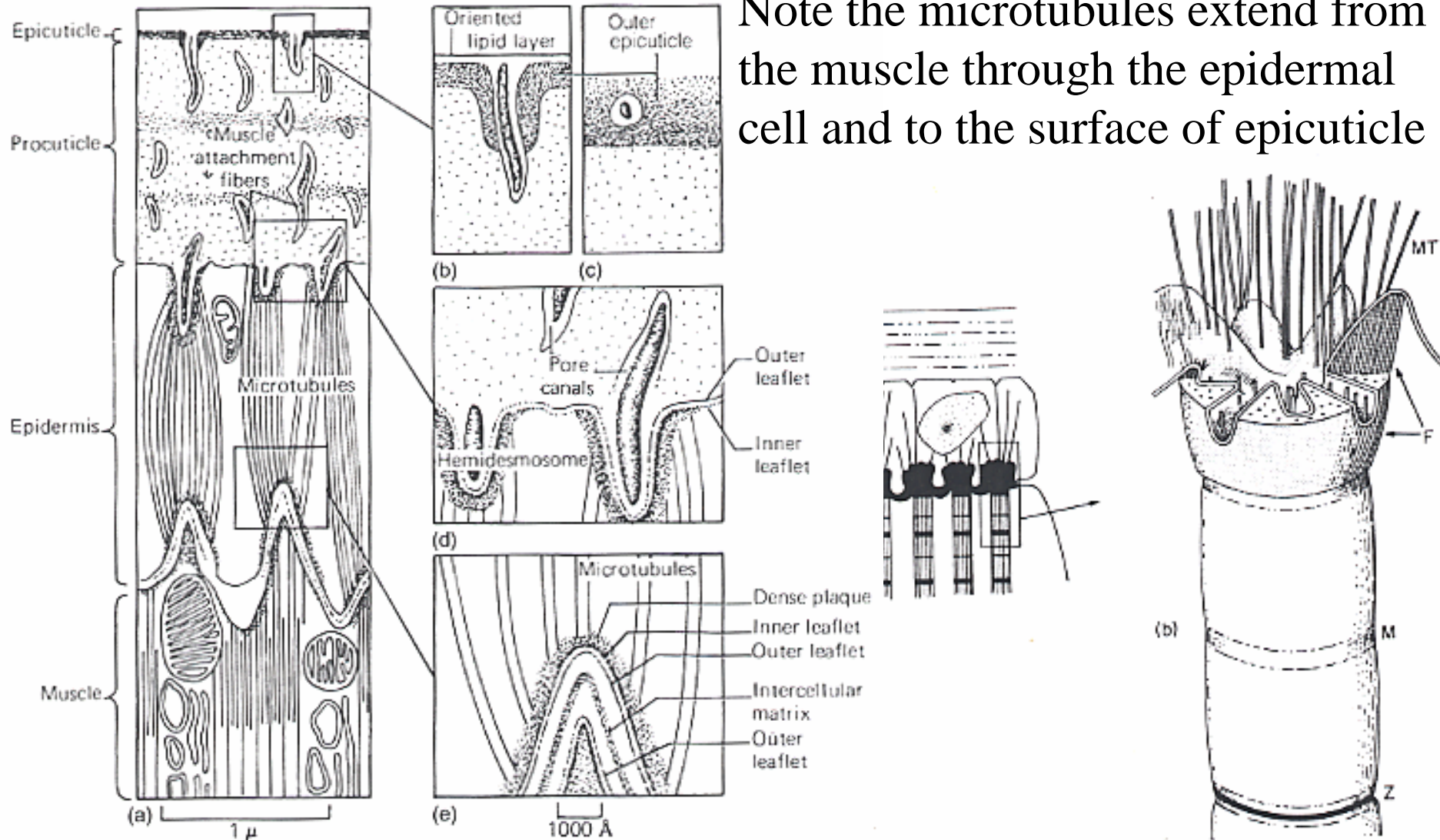

# Lateral, abdominal, cuticular plaques of *Tabanus nigrovittatus*

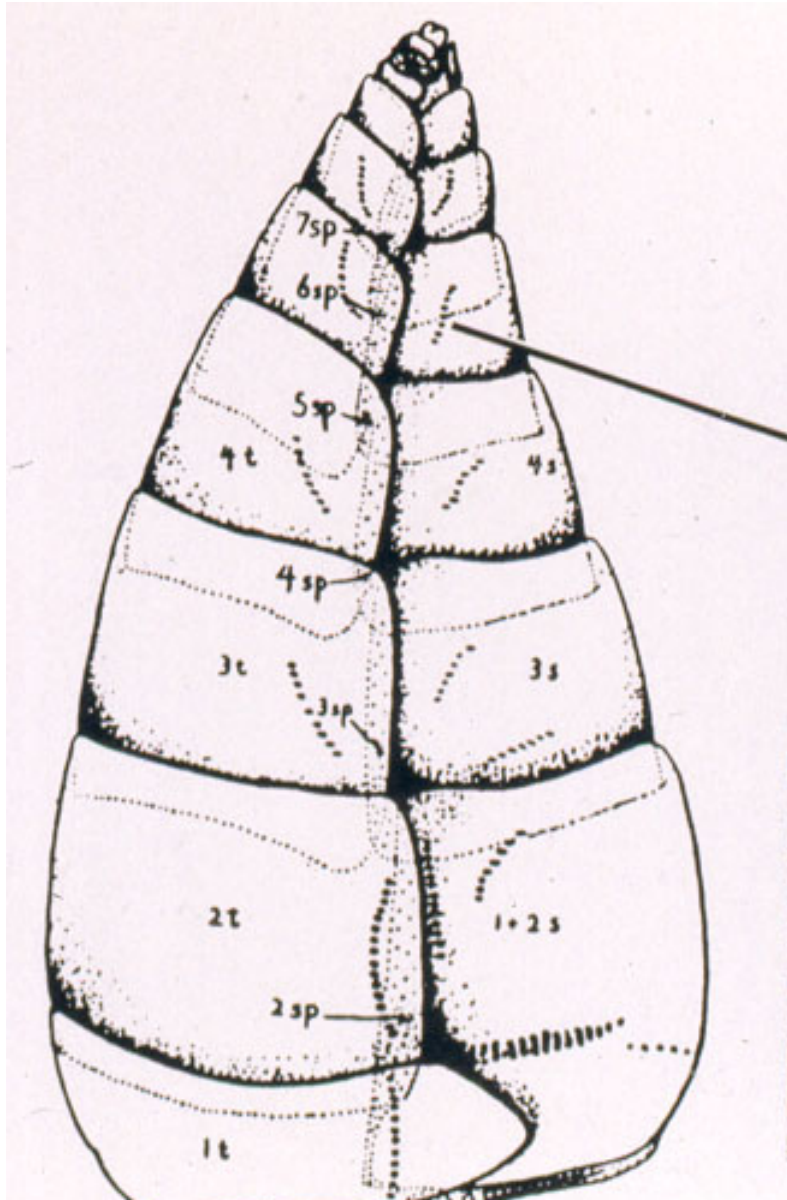

Research on cuticular plaques in *Tabanus nigrovittatus*. Originally people thought these plaques were sensory. No research on them. When sections were made through the plaques, we found that the tonofibrillae (T) had penetrated the cuticle. These are remnants of muscles used by adult to exit the puparium. Separates the

Orthorrhaphous from Cyclorrhaphous

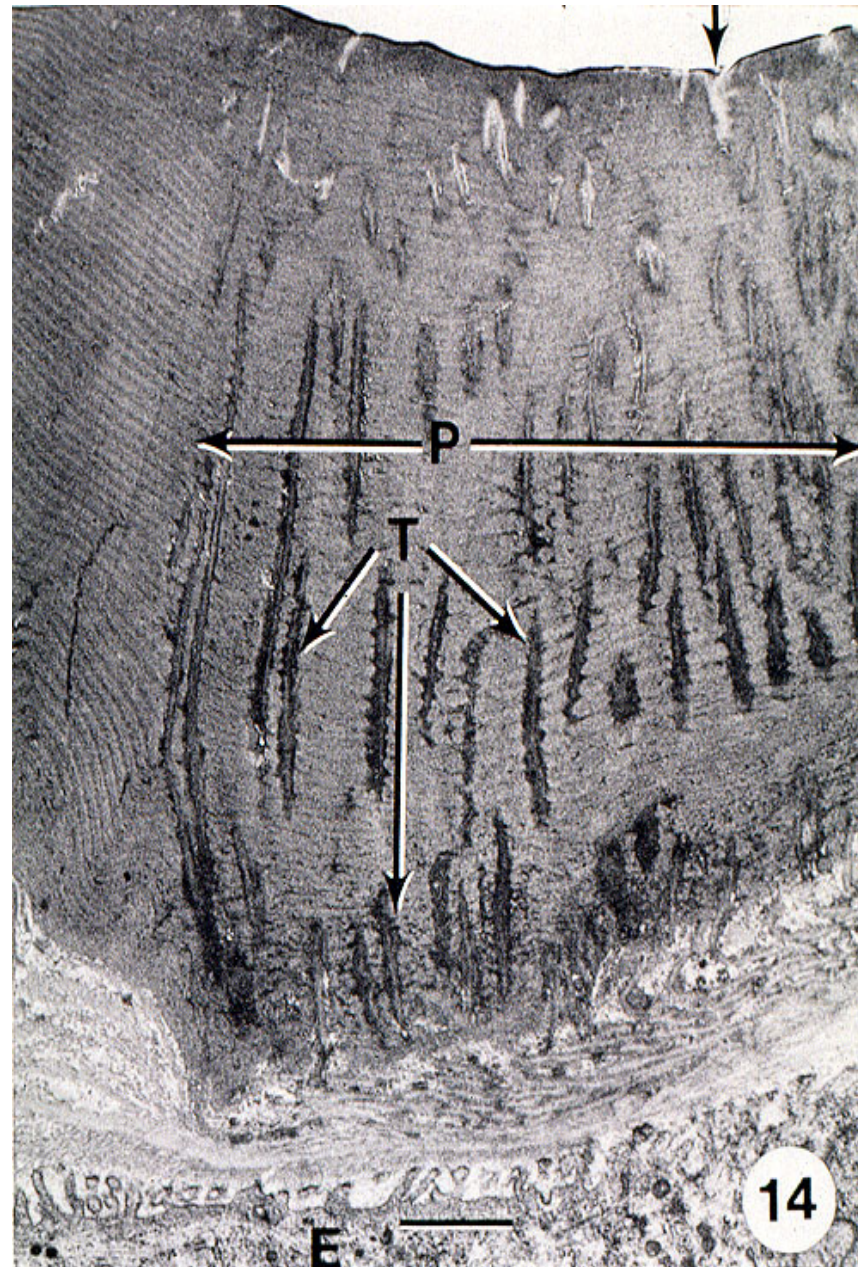
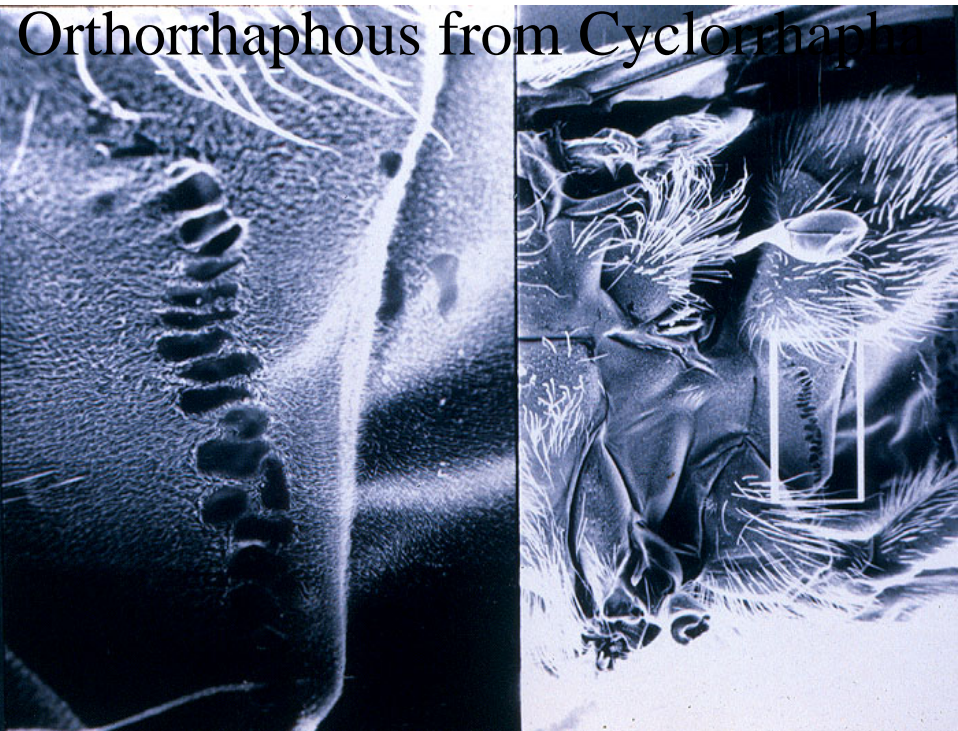

**NOW ON TO THE MUSCULAR SYSTEM**